

# Wind Turbine Technology

## Lecture 1

Basics  
and key  
calculations



22

Dr Konstantinos Ninikas  
Konstantinos.Ninikas@gcu.ac.uk

# Wind turbines

All wind turbines have in common that they use wind power to produce electric energy. Though the way this is done may differ.

Today there are essentially two different types of wind turbines that are functioning in quite different ways.

There are turbines with blades rotating about a horizontal axis which is most commonly used,

and turbines that use a rotating motion about a vertical axis



**HAWT**  
(Horizontal Axis  
Wind Turbines)

**VAWT**  
(Vertical Axis  
Wind Turbines)

# Wind turbines



1. Foundation
2. Tower
3. Nacelle
4. Rotor blades
5. Hub
6. Transformer

# Wind turbines

Foundations / software for  
design development

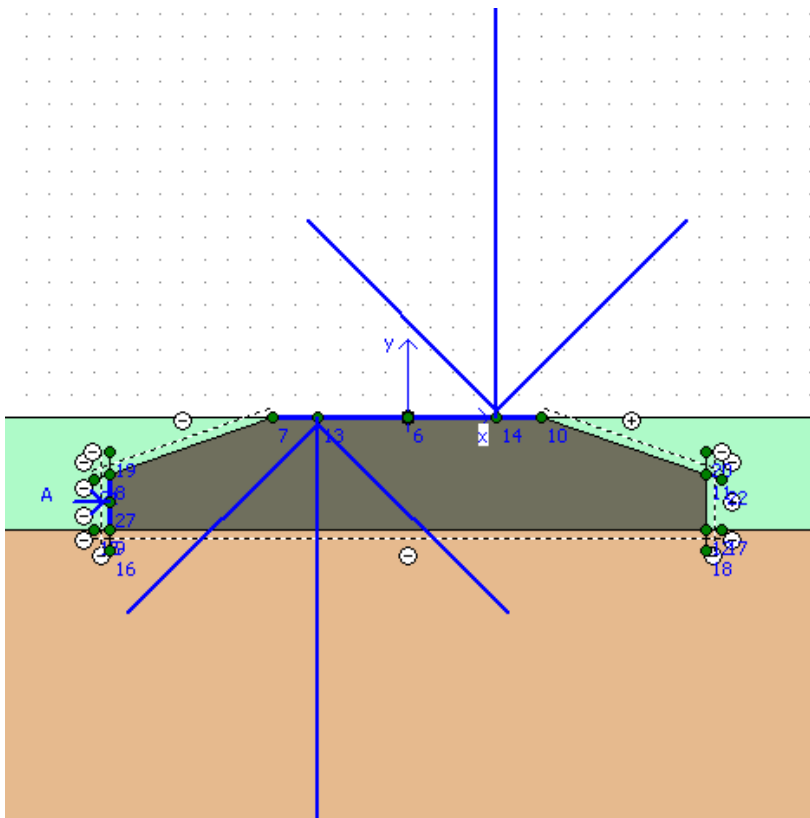

## Structural design details

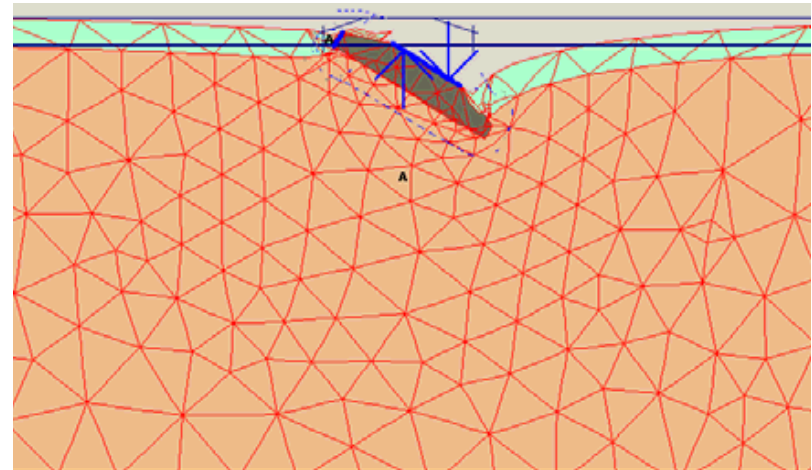

# Installation

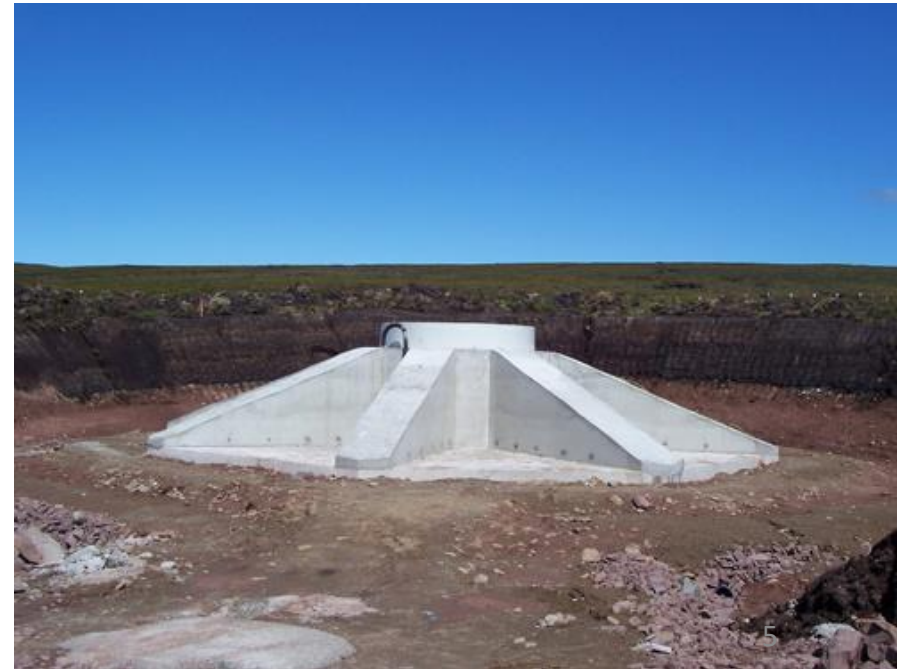

# Wind turbines installed

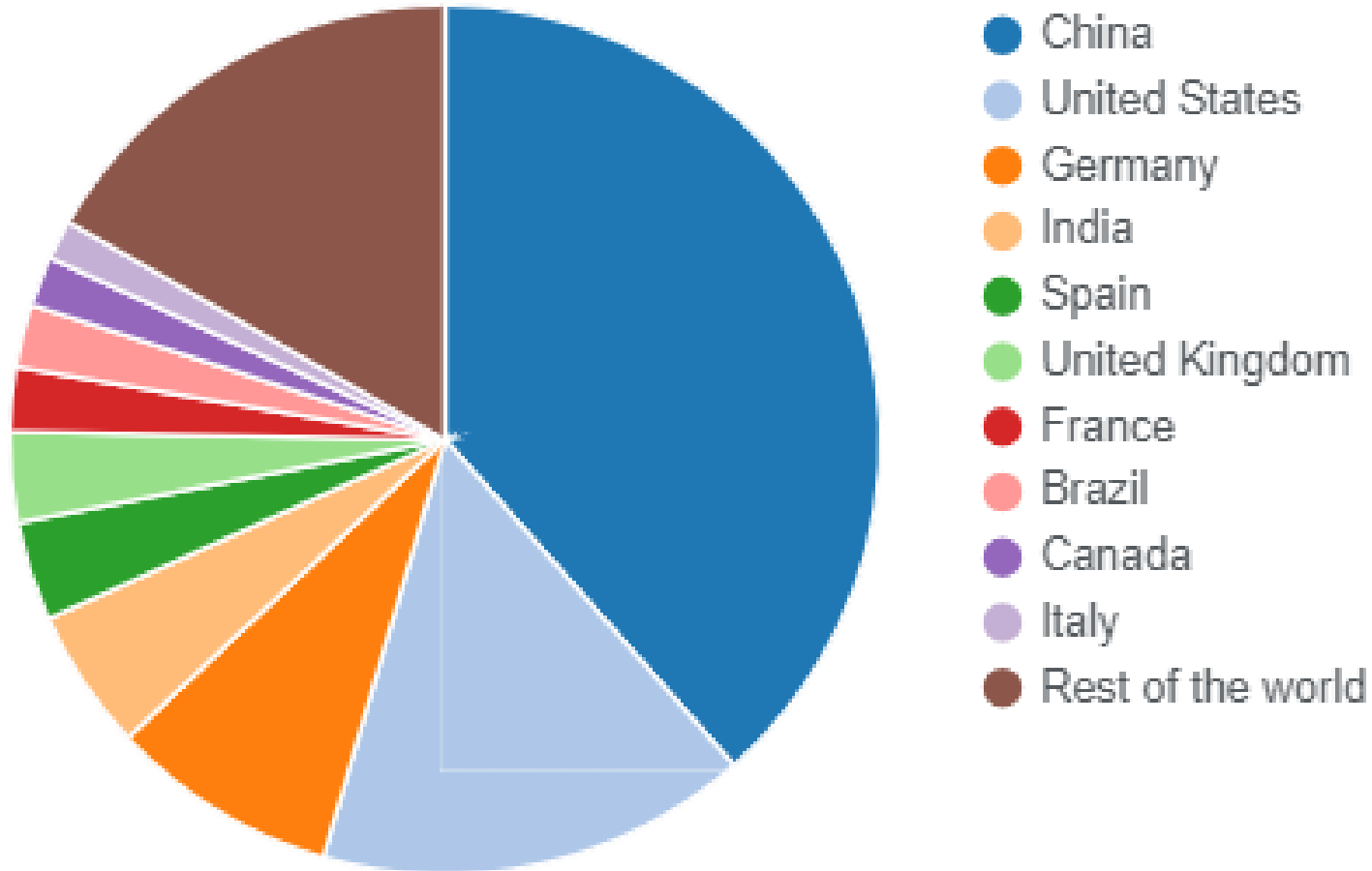





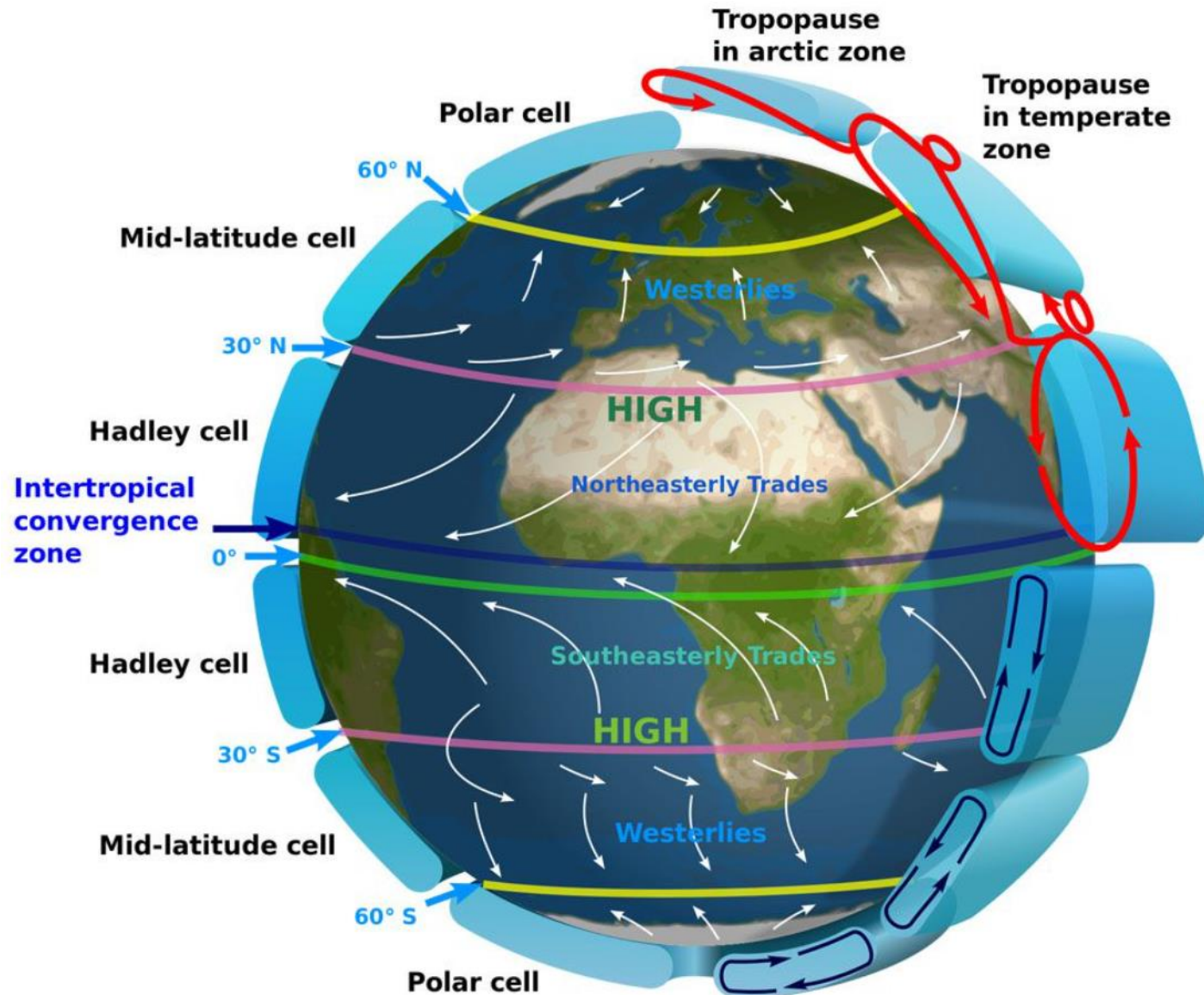





Beaufort no	Wind speed m/s	Description	Wind turbine effects
0	0 – 0.4	Calm	None
1	0.4 – 1.8	Light	None
2	1.8 – 3.6	Light	None
3	3.6 – 5.8	Light	Start-up by turbines for light winds
4	5.8 – 8.5	Moderate	
5	8.5 – 11	Fresh	Useful power generation
6	11 – 14	Strong	Rated range at full capacity
7	14 – 17	Strong	Full capacity
8	17 – 21	Gale	Shut-down or self-stalling initiated
9	21 – 25	Gale	All machines shut down or stalled
10	25 – 29	Strong Gale	Design criteria against damage
11	29 – 34	Strong Gale	Only very strong machines survive
12	34 +	Hurricane	Serious damage likely

# Prevailing winds



# Wind turbine capacity

Installed wind power capacity (MW) <sup>[16][17][18][19][20][21][22][23]</sup>

#	Country or territory	2014 <sup>[24]</sup>	2015 <sup>[3]</sup>	2016 <sup>[25]</sup>	2017 <sup>[26]</sup>	2018 <sup>[27]</sup>	2019 <sup>[15]</sup>	2020 <sup>[28]</sup>
1	 China	114,763	145,104	168,690	188,232	211,392	236,320	281,993
–	 European Union	128,752	141,579	153,730	169,319	178,826	192,020	201,507
2	 United States	65,879	74,472	82,183	89,077	96,665	105,466	117,744
3	 Germany	39,165	44,947	50,019	56,132	59,311	61,357	62,184
4	 India	22,465	27,151	28,665	32,848	35,129	37,506	38,559
5	 Spain	22,987	23,025	23,075	23,170	23,494	25,808	27,089
6	 United Kingdom	12,440	13,603	15,030	18,872	20,970	23,515	24,665
7	 France	9,285	10,358	12,065	13,759	15,309	16,643	17,382
8	 Brazil	5,939	8,715	10,740	12,763	14,707	15,452	17,198
9	 Canada <sup>[29]</sup>	9,694	11,205	11,898	12,239	12,816	13,413	13,577
10	 Italy	8,663	8,958	9,257	9,479	9,958	10,512	10,839

# Global wind resources

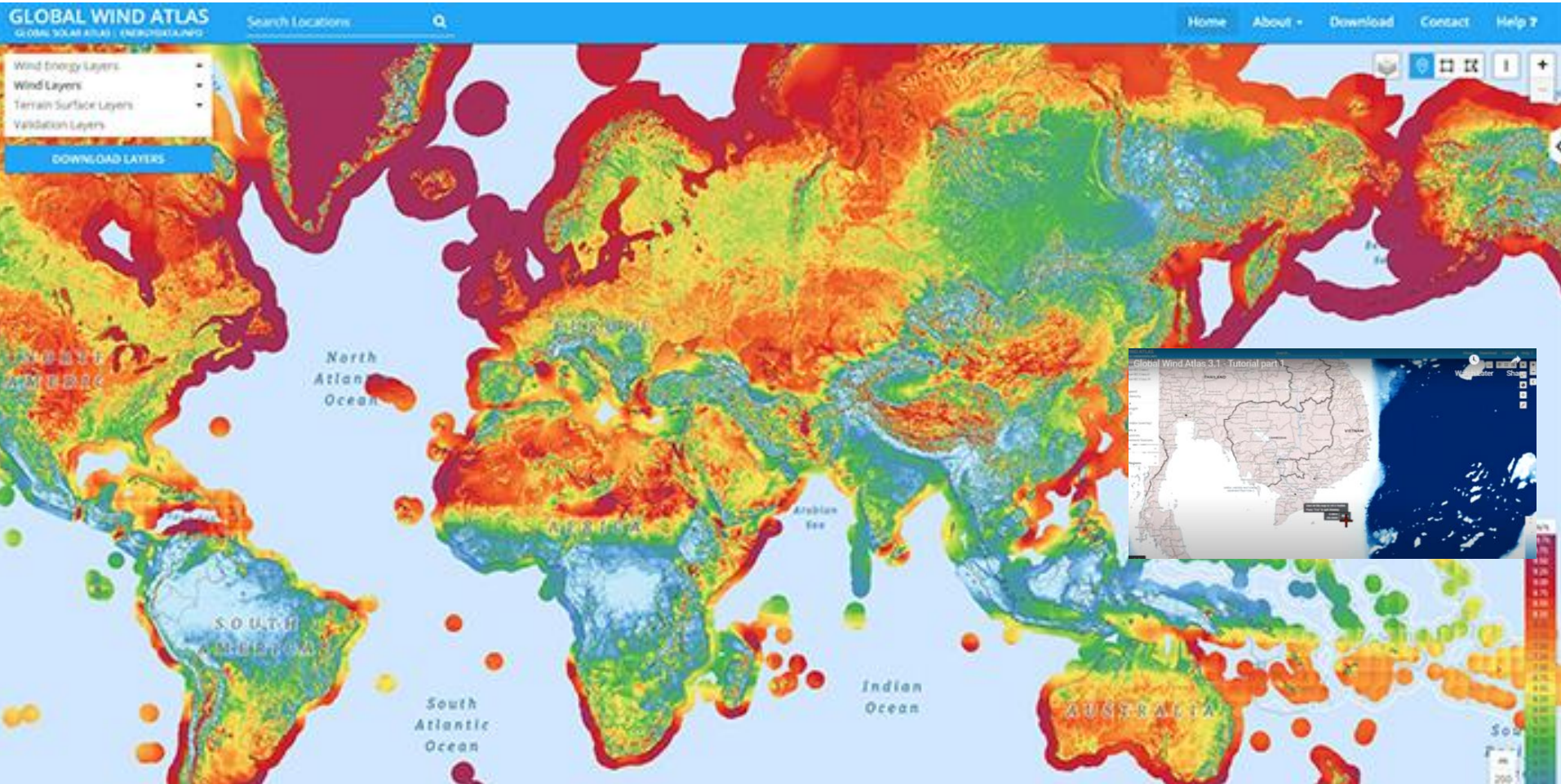

<https://globalwindatlas.info/>

# Wind turbine capacity

## EUROPEAN WIND ENERGY GENERATION | 2018

**14%**

of EU's electricity demand

**24%**

Average capacity factor

41% 28% 24% 21% 19%



Highest wind energy penetration rates

ONSHORE

**160 GW**

onshore wind capacity

**12%**

onshore wind of EU's electricity demand

**22%**

average onshore wind capacity factor

OFFSHORE

**18.5 GW**

offshore wind capacity

**2%**

offshore wind of EU's electricity demand

**37%**

average offshore wind capacity factor

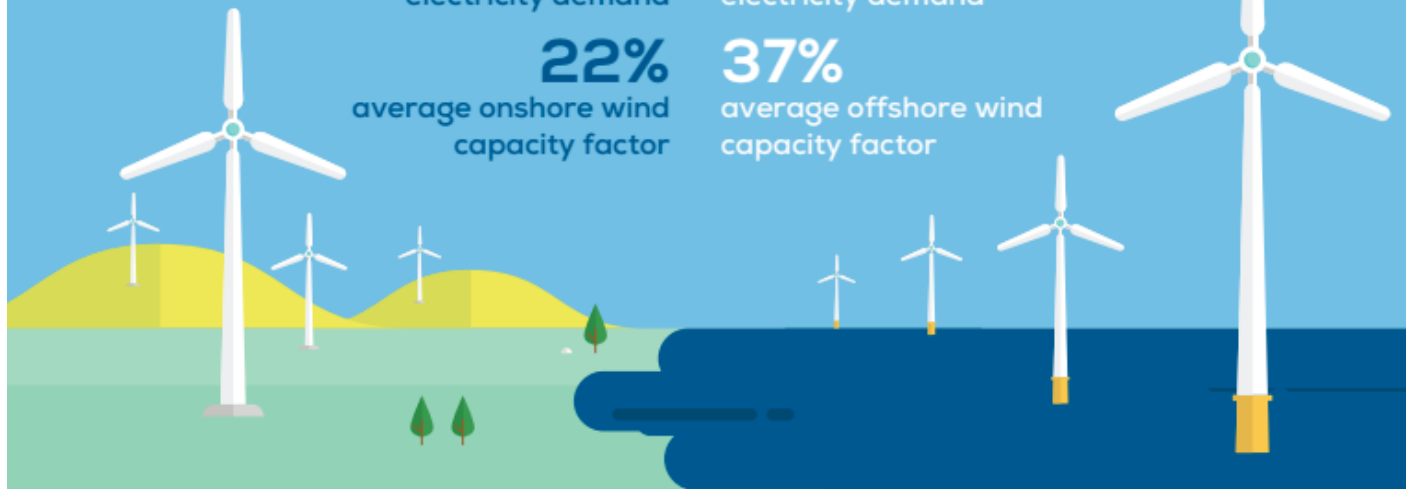

# Vertical Axis Wind Turbines (VAWT)

The axis of rotation is perpendicular to the wind

**Savonius**

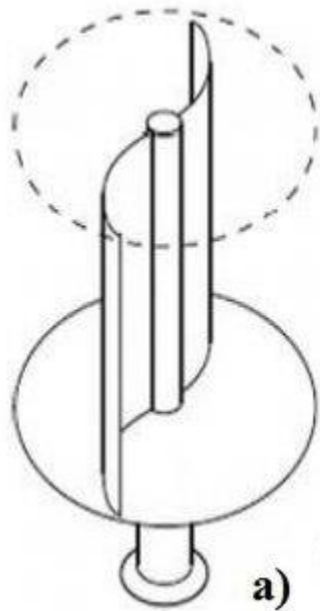

**Darrieus-rotor**

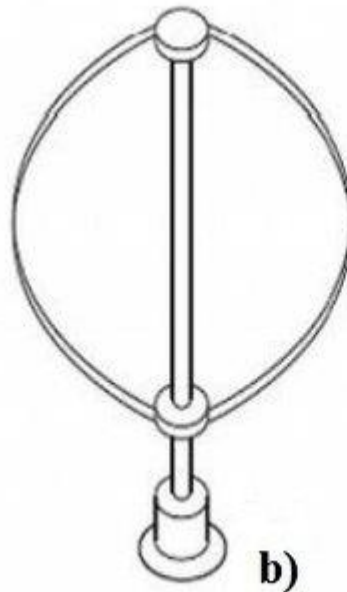

**H-Darrieus**

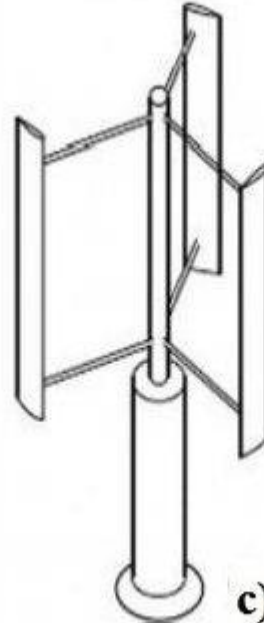

**Helix shape**

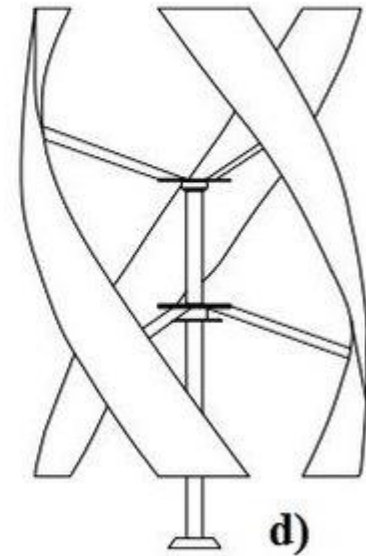

# Horizontal Axis Wind Turbines (HAWT)



Two blades

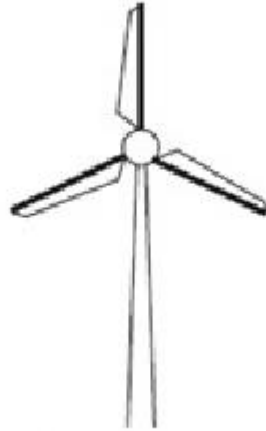

Three blades



Four blades

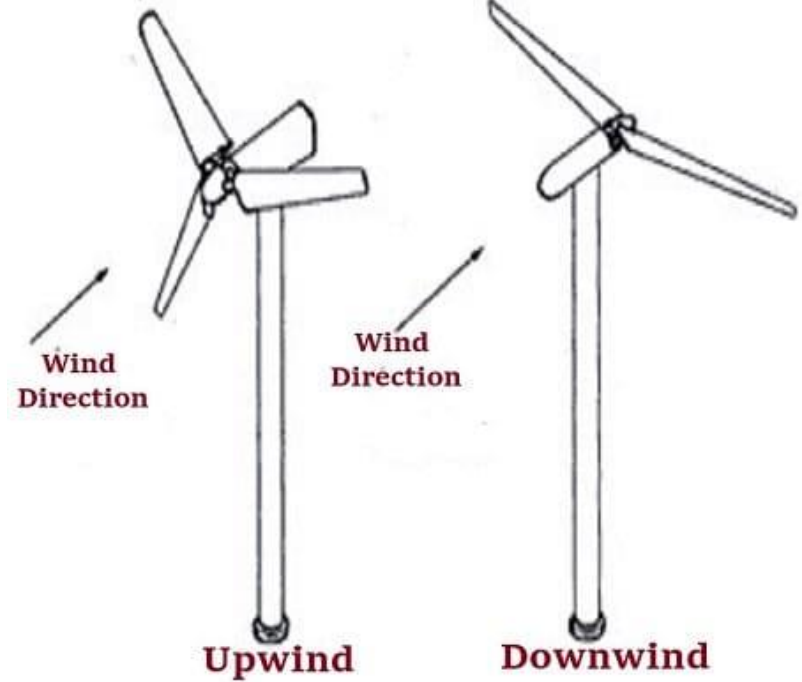

Upwind

Downwind

# Horizontal Axis Wind Turbines (HAWT)

The axis of rotation is parallel to the wind

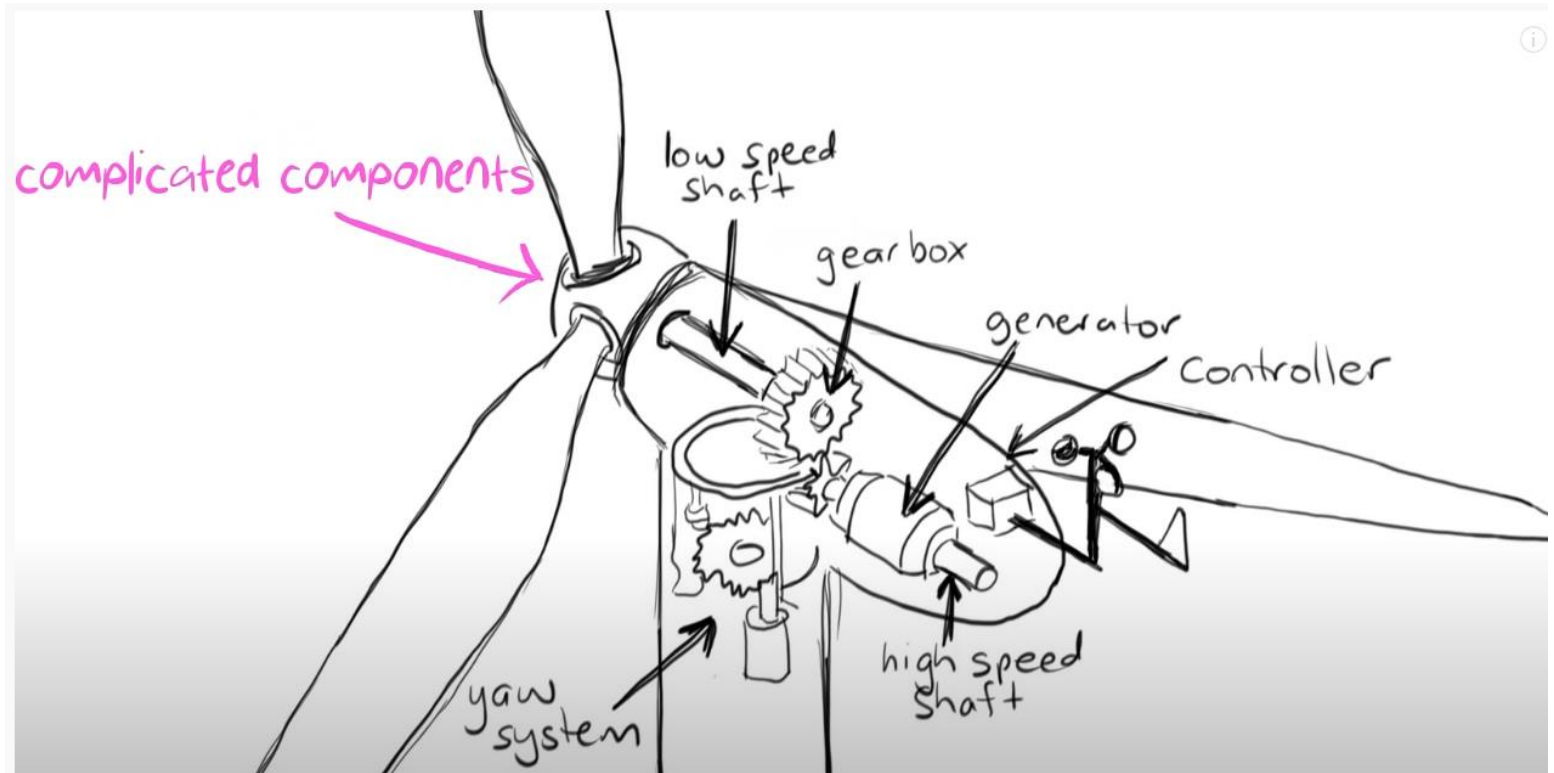

If you will double the wind speed, you get eight times more power

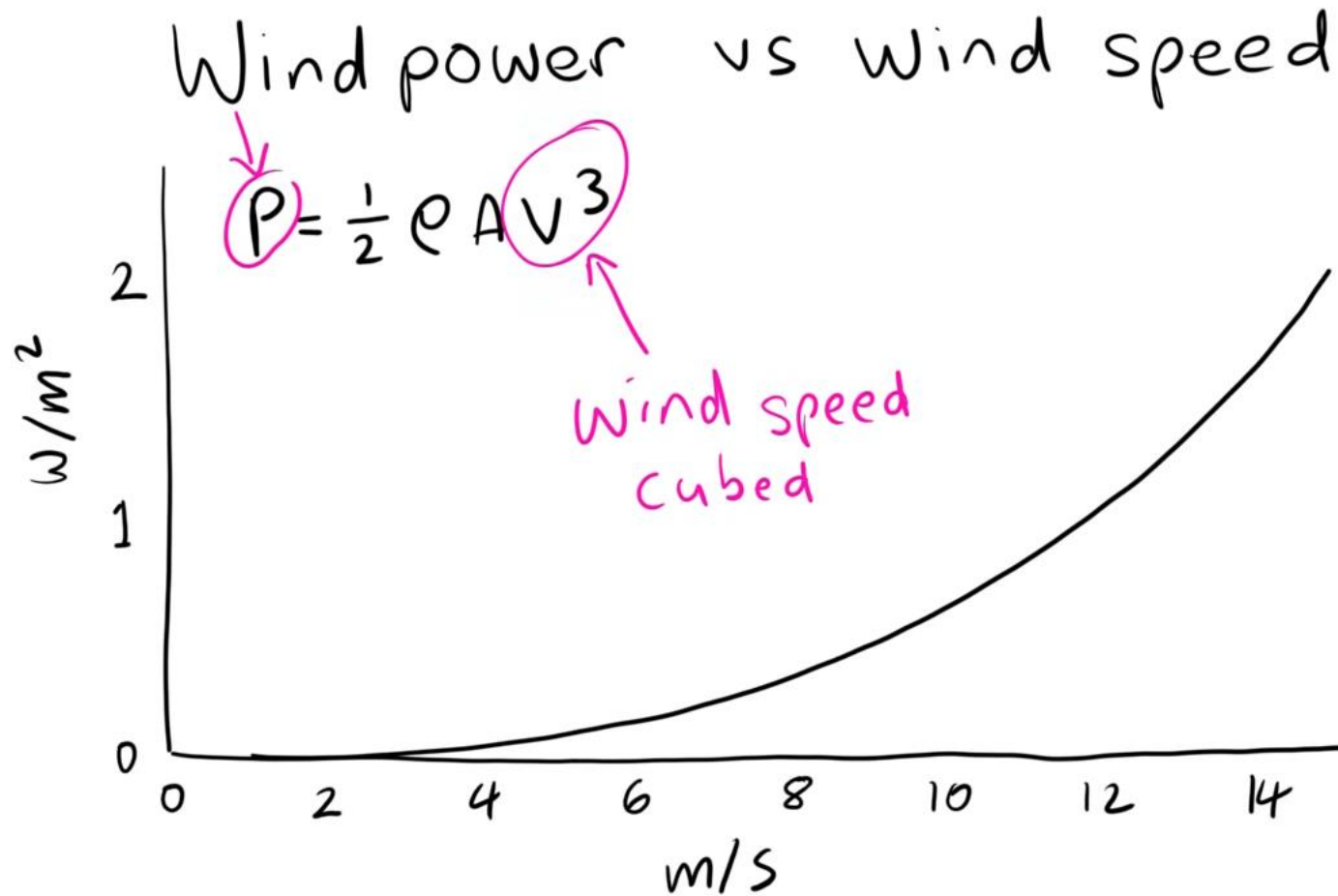

## VAWT & HAWT

# Urban wind resources in perspective



40% efficient @ 5m/s  
(very good urban VAWT)



30% efficient @ 5m/s  
(less efficient urban wind turbine)

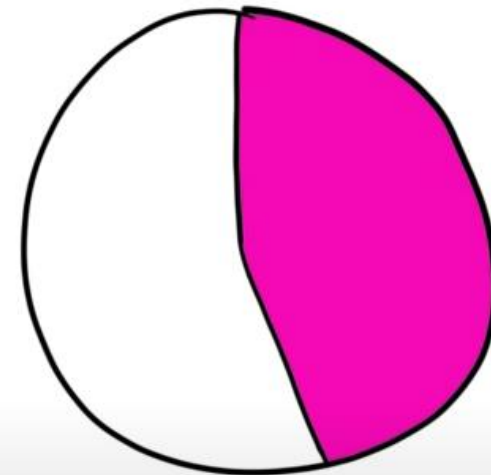

47% efficient @ 10m/s  
(typical industrial-scale HAWT)

## Example VAWT specifications

Manufacturer, model	Swept area (m <sup>2</sup> )	Power rating (kW)	Rated wind speed (m/s)	Efficiency
		(manufacturer specs)		(calculated)
<b>WePower, Falcon 12kW</b>	37.2	12	13	24%
<b>quietrevolution, qr5</b>	13.6	3.3	11	30%
<b>Urban Green Energy, Eddy</b>	2.1	0.65	12	29%
<b>Windspire Energy,</b>	7.43	1.2	11	20%
<b>Urban Green Energy, UGE-4 K</b>	12.5	4	12	30%
<b>4navitas</b>	196	55	11	34%
<b>Agile Wind Power</b>	1728	750	12	41%

Extra efficiency means... extra complexity

# Wind turbines



[www.renewablwedevices.com](http://www.renewablwedevices.com)



# Wind turbine basics

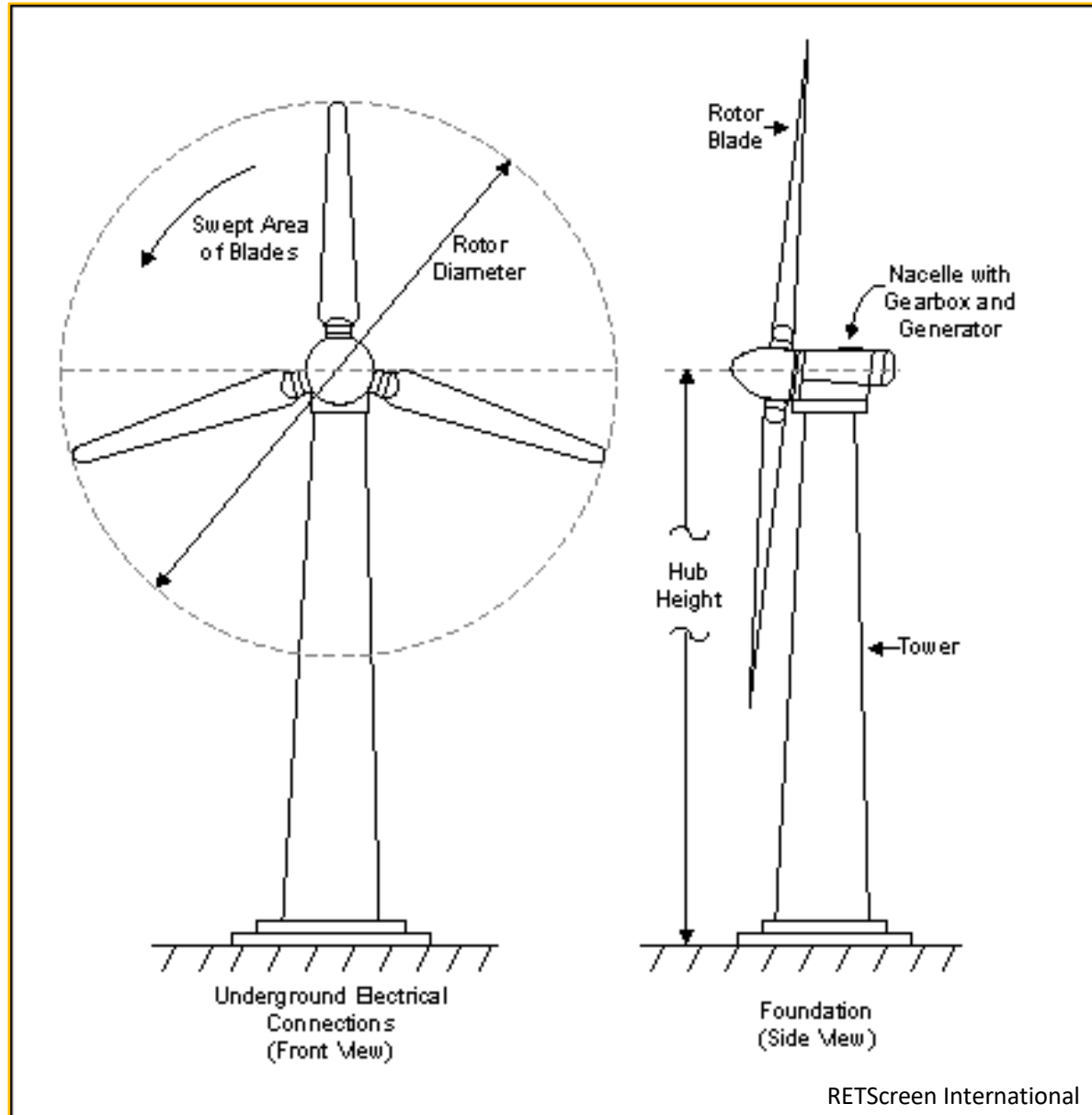

# Turbine size characteristics

class	<i>small</i>			<i>intermediate</i>				<i>large</i>			
Rated power $P_T$ (kW)	10	25	50	100	150	250	500	1000	2000	3000	4000
Diameter $D$ (m)	6.4	10	14	20	25	32	49	64	90	110	130
Period $T$ (s)	0.3	0.4	0.6	0.9	1.1	1.4	2.1	3.1	3.9	4.8	5.7

# Cost

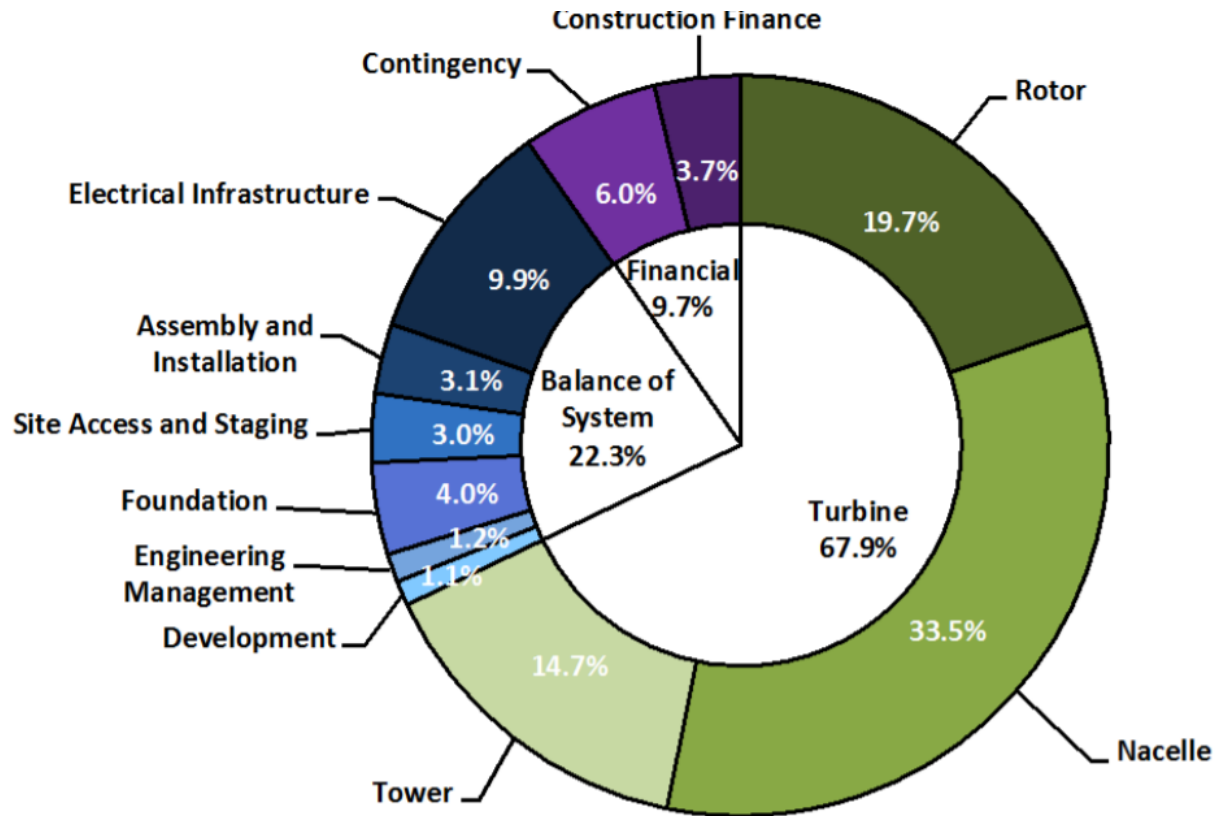

CapEx for the land-based reference wind power plant project

Source: NREL

# Cost

	2.32-MW Land-Based Turbine (\$/kilowatt [kW]) Market	2.32-MW Land-Based Turbine (\$/MWh) Market
<b>Rotor module</b>	<b>317</b>	<b>6.9</b>
<b>Blades</b>	<b>203</b>	<b>4.4</b>
Pitch assembly	66	1.4
<b>Hub assembly</b>	<b>48</b>	<b>1.1</b>
<b>Nacelle module</b>	<b>539</b>	<b>11.8</b>
Nacelle structural assembly	108	2.4
<b>Drivetrain assembly</b>	<b>211</b>	<b>4.6</b>
Nacelle electrical assembly	184	4.0
<b>Yaw assembly</b>	<b>35</b>	<b>0.8</b>
<b>Tower module</b>	<b>237</b>	<b>5.2</b>
<b>Turbine capital cost</b>	<b>1,094</b>	<b>23.8</b>
<b>Development cost</b>	<b>17</b>	<b>0.4</b>
<b>Engineering management</b>	<b>20</b>	<b>0.4</b>
<b>Foundation</b>	<b>65</b>	<b>1.4</b>
<b>Site access and staging</b>	<b>48</b>	<b>1.1</b>
<b>Assembly and installation</b>	<b>49</b>	<b>1.1</b>
<b>Electrical infrastructure</b>	<b>160</b>	<b>3.5</b>
<b>Balance of system</b>	<b>360</b>	<b>7.8</b>
<b>Construction financing cost</b>	<b>60</b>	<b>1.3</b>
<b>Contingency fund</b>	<b>97</b>	<b>2.1</b>
<b>Financial costs</b>	<b>157</b>	<b>3.4</b>
<b>Total capital expenditures</b>	<b>1,610</b>	<b>35.1</b>

**Electricity generation (TWh/yr)**

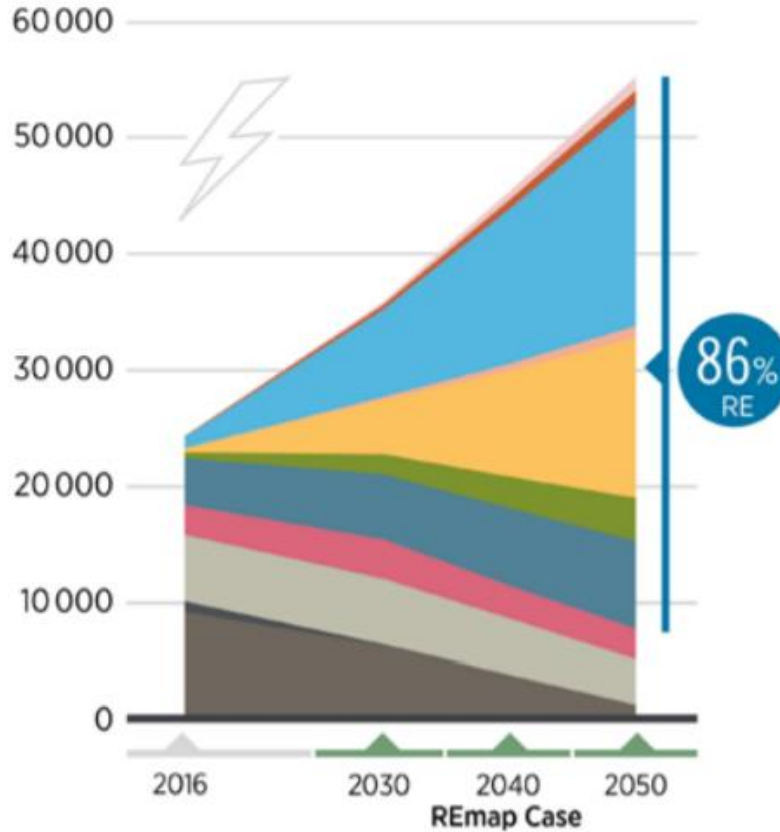

**Total installed power capacity (GW)**

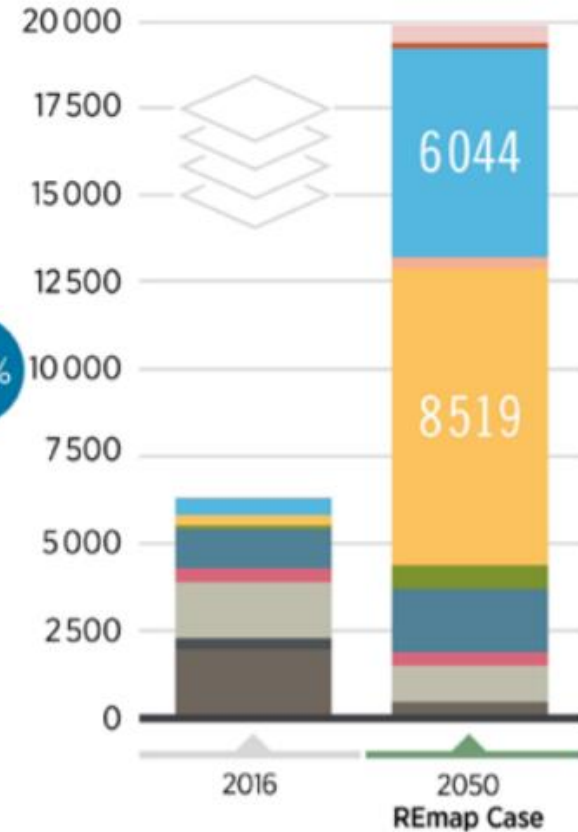

- Coal
- Nuclear
- Solar PV
- Geothermal
- Oil
- Hydro (excl. pumped)
- CSP
- Others (incl. marine)
- Natural gas
- Bioenergy
- Wind (onshore and offshore)

Wind is expected to be the largest generating source, supplying more than one-third of total electricity generation needs by 2050.

Source: IRENA, 2019a.

# Wind Physics

## Available wind power

$$\text{Kinetic Energy} = \frac{1}{2} mv^2$$

Particles of air have low mass so must look at mass flow in a specific area

$$\frac{dm}{dt} = \rho AV$$

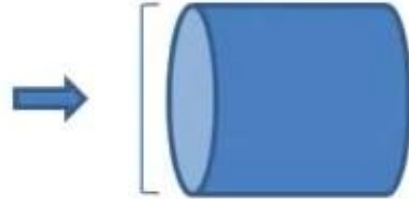

Mass flow of air through disc of area - A

$$P = \frac{1}{2} \frac{dm}{dt} v^2 = P = \frac{1}{2} \rho A v^3$$

# Wind Physics

## Available wind power

- Power in the wind (W) =  $\frac{1}{2} \rho A V^3$ 
  - Effect of wind speed, V
  - Effect of swept area, A
  - Effect of air density,  $\rho$

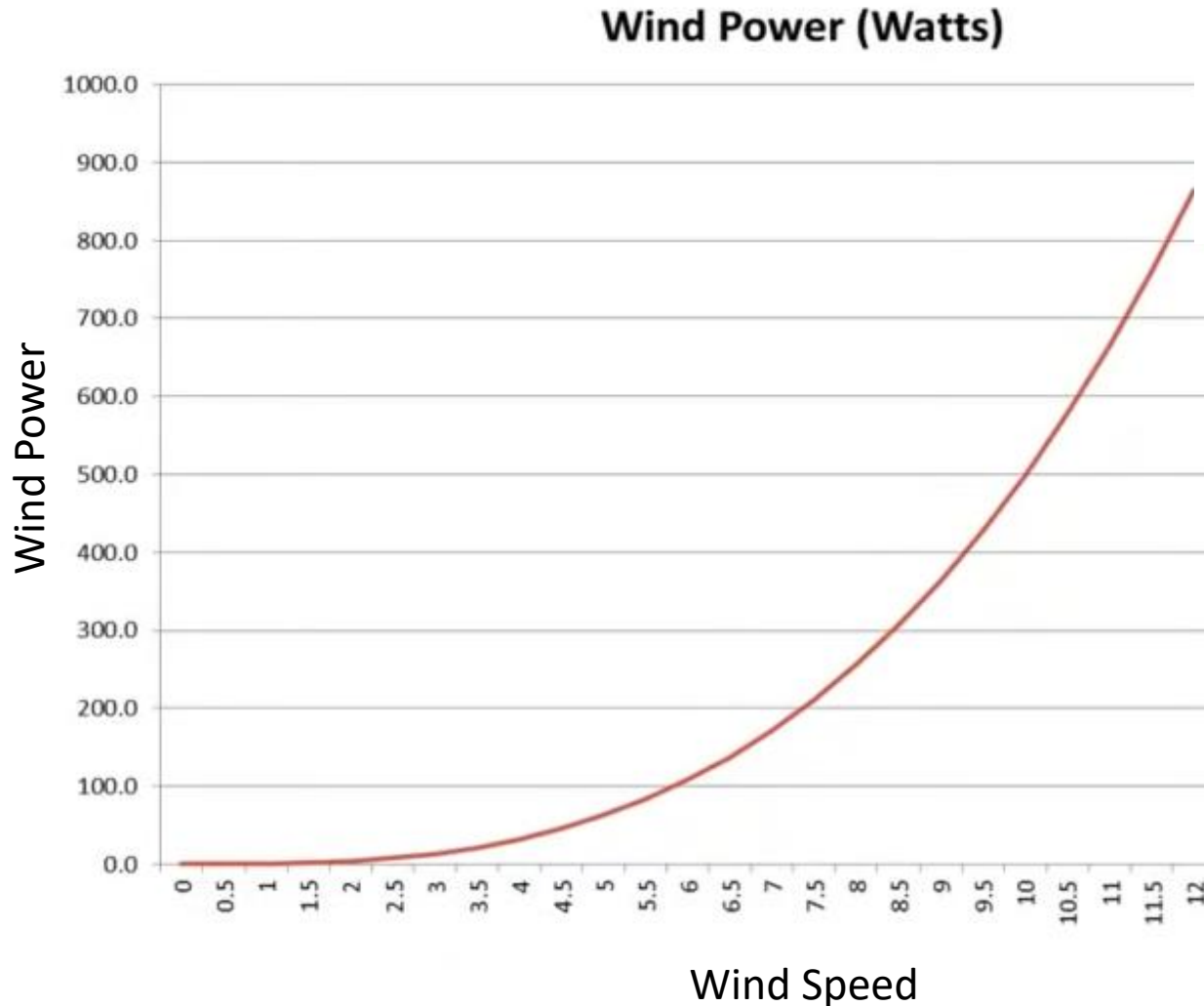

— Wind Power (Watts)

### Assumptions

- Air density 1 kg/m<sup>3</sup>
- Swept area 1 m<sup>2</sup>

# Wind Physics

## Available wind power

$$\text{Power in the wind (W)} = \frac{1}{2} \rho A V^3$$

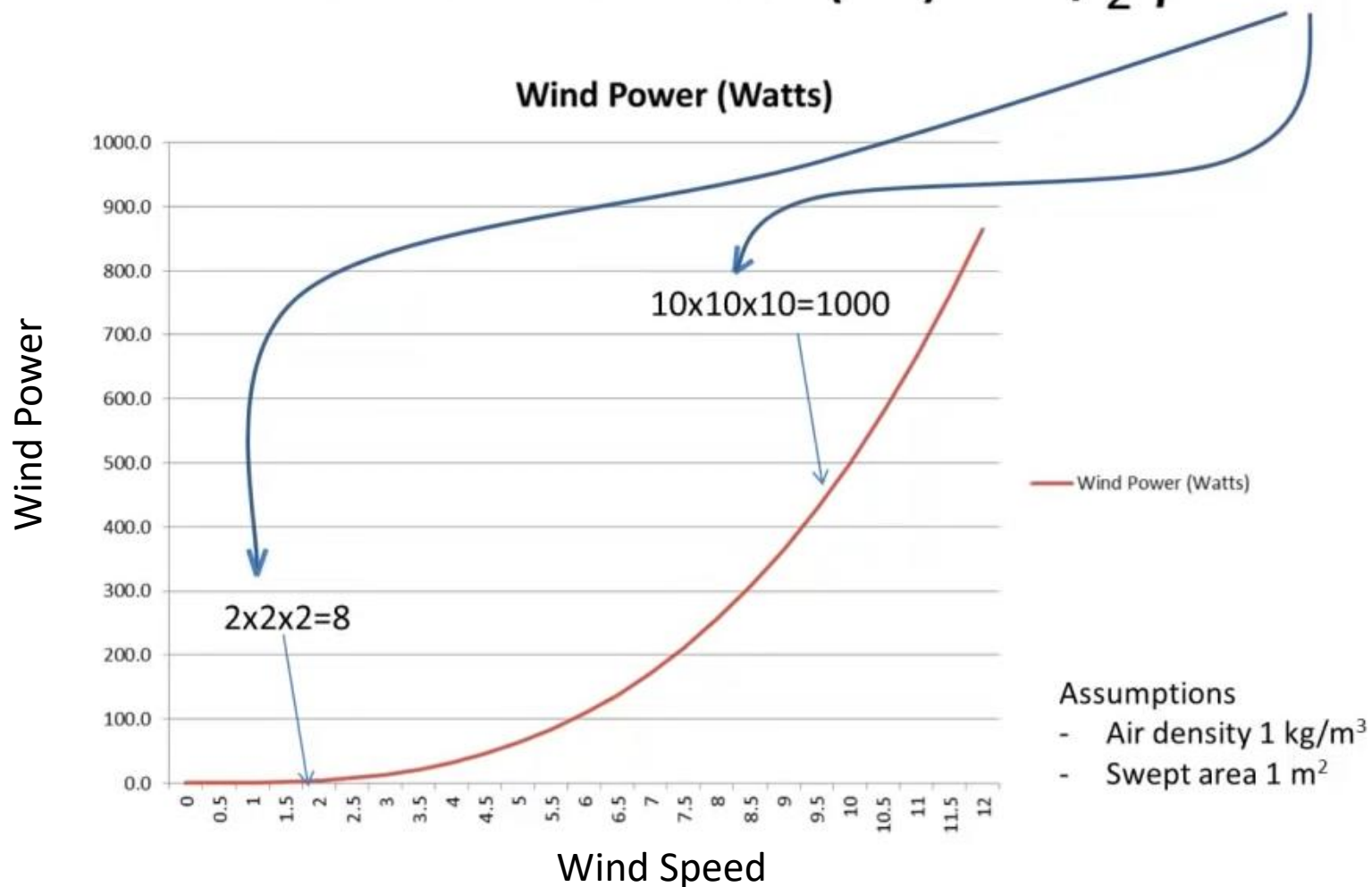

# Betz Limit, Tip Speed, Efficiency

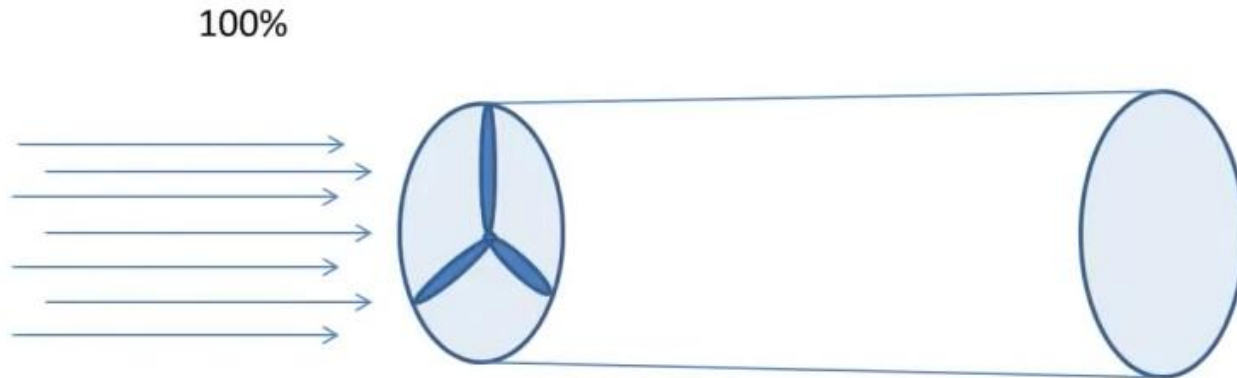

Spinning blades cause wind behind turbine to rotate. Faster spinning blades cause less rotation and have less wake rotation losses

Every generation system is less than 100% efficient, we always have losses!

# Betz Limit, Tip Speed, Efficiency

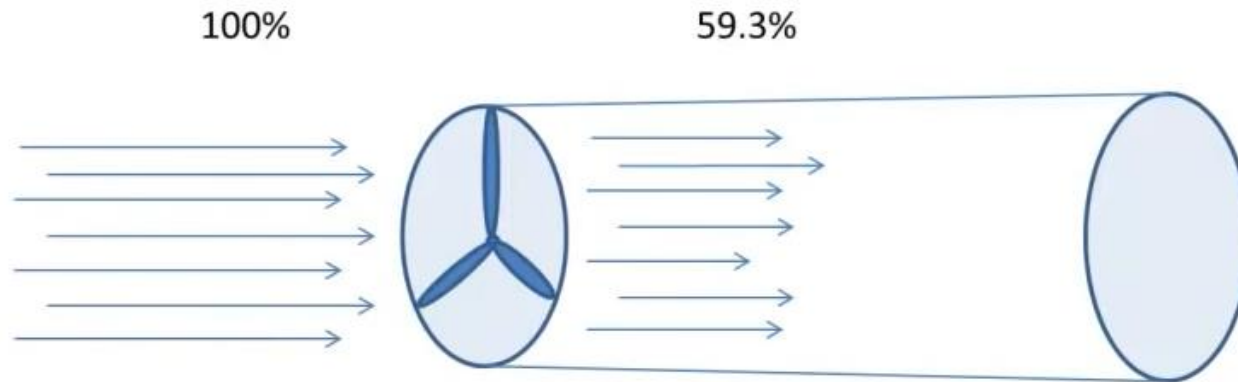

Spinning blades cause wind behind turbine to rotate. Faster spinning blades cause less rotation and have less wake rotation losses

Maximum efficiency calculated by Albert Betz

# Betz Limit, Tip Speed, Efficiency

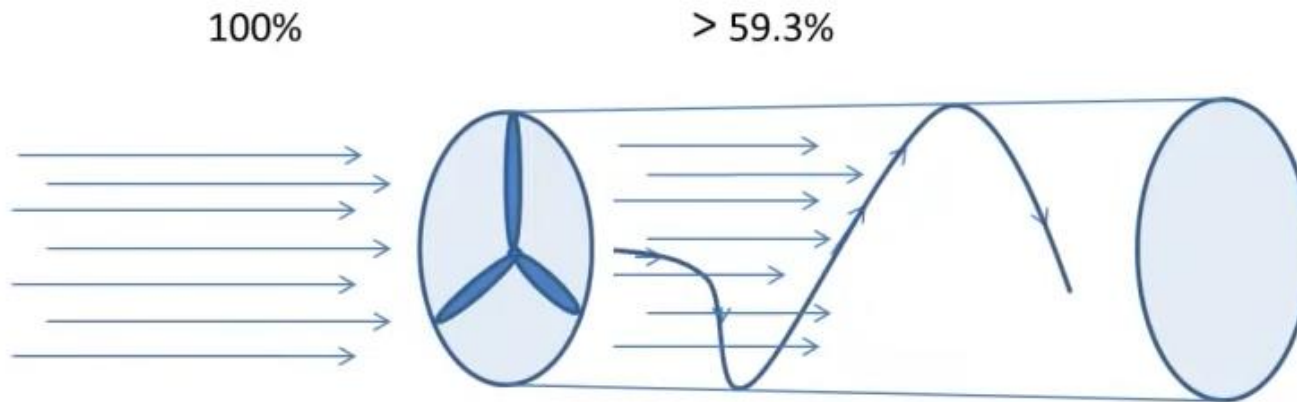

Spinning blades cause wind behind turbine to rotate. Faster spinning blades cause less rotation and have less wake rotation losses

Unfortunately there is more waste energy due to the rotation

# Wind Turbines

## Choosing a Turbine

Savonius

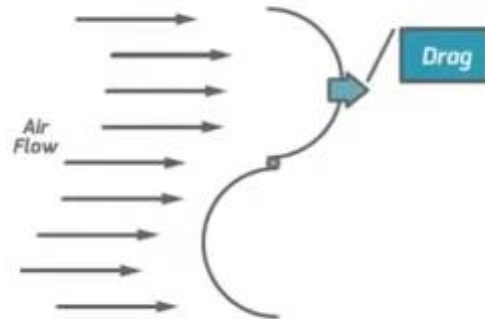
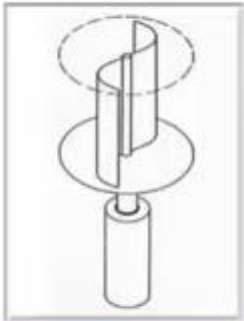

Drag: Slow Tip Speeds

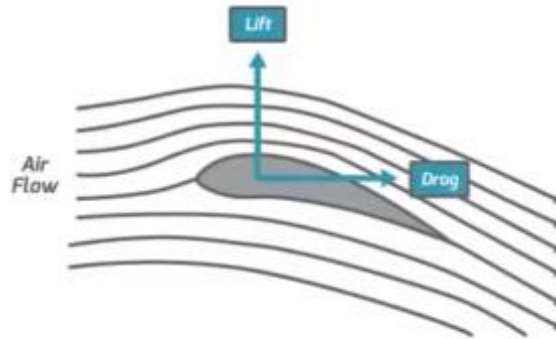

Lift: Fast Tip Speeds



## Three Types of Small Turbines

- Savonius →  
SLOW TIP SPEED!

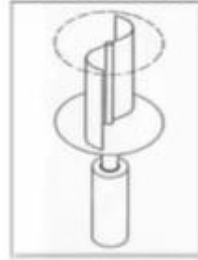

- Darrieus →  
MODERATE TO FAST TIP SPEED!



- Horizontal Axis →  
FAST TIP SPEED!



## Wind Power vs Power Curve for 1 kW turbine

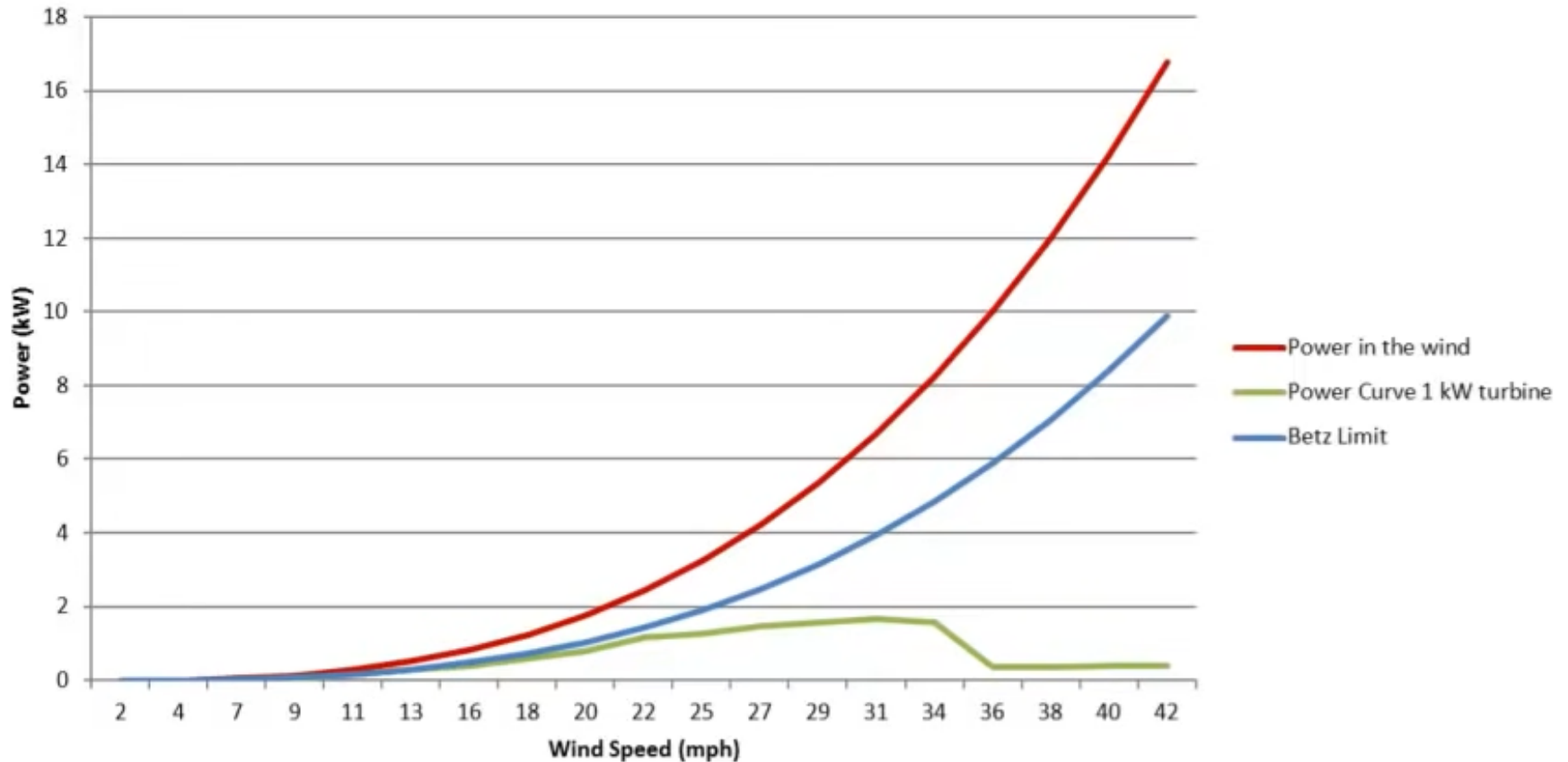

The power curves drop of about 34 miles.  
This is a protection measure against high wind speeds.

## Basic facts

• Power in the wind (W) =  $\frac{1}{2} \rho A V^3$

- Effect of wind speed,  $V$
- Effect of swept area,  $A$
- Effect of air density,  $\rho$

Faster wind LOTS more power!

Bigger turbine more power!

$\approx 1$  so it doesn't matter much

## Basic facts

- Power in the wind (W) =  $\frac{1}{2} \rho A V^3$
- High Wind Speeds
  - Open areas are best
  - Up high
  - Never put a turbine on a building!

# Choosing a location

Avoid slow wind  
Avoid turbulent wind  
Never on buildings

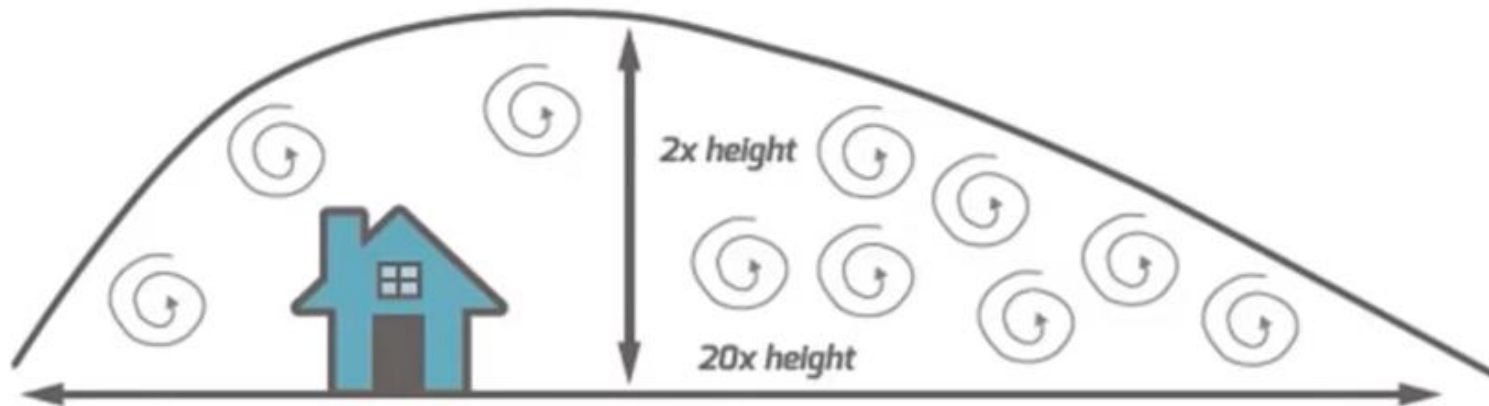

correct location & correct design to get you more electricity

# Siting of wind turbines

- Tops of hills are good...

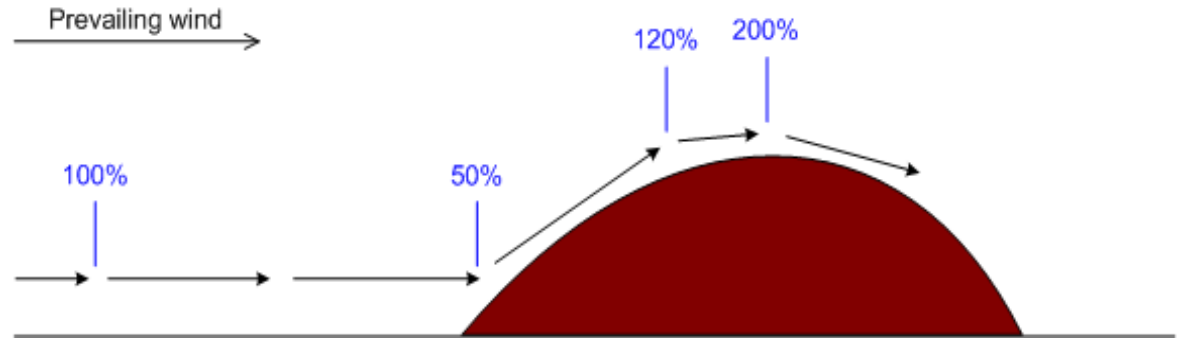

- ... but avoid sharp ridges

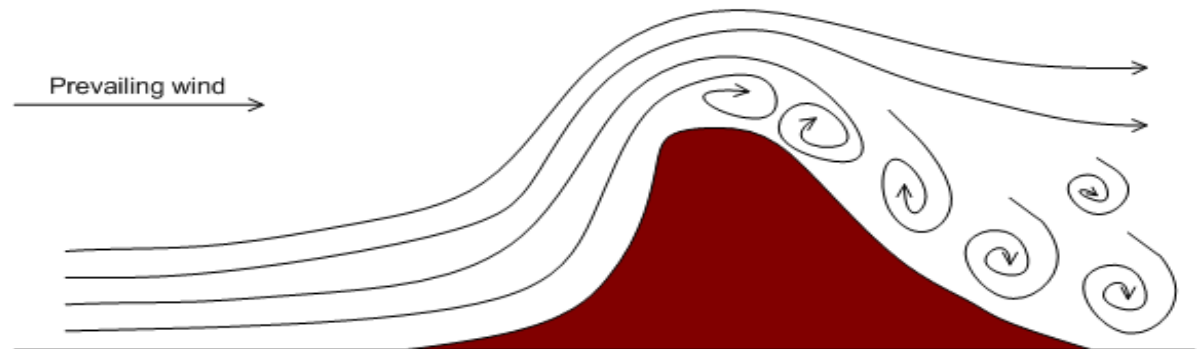

# Siting of wind turbines

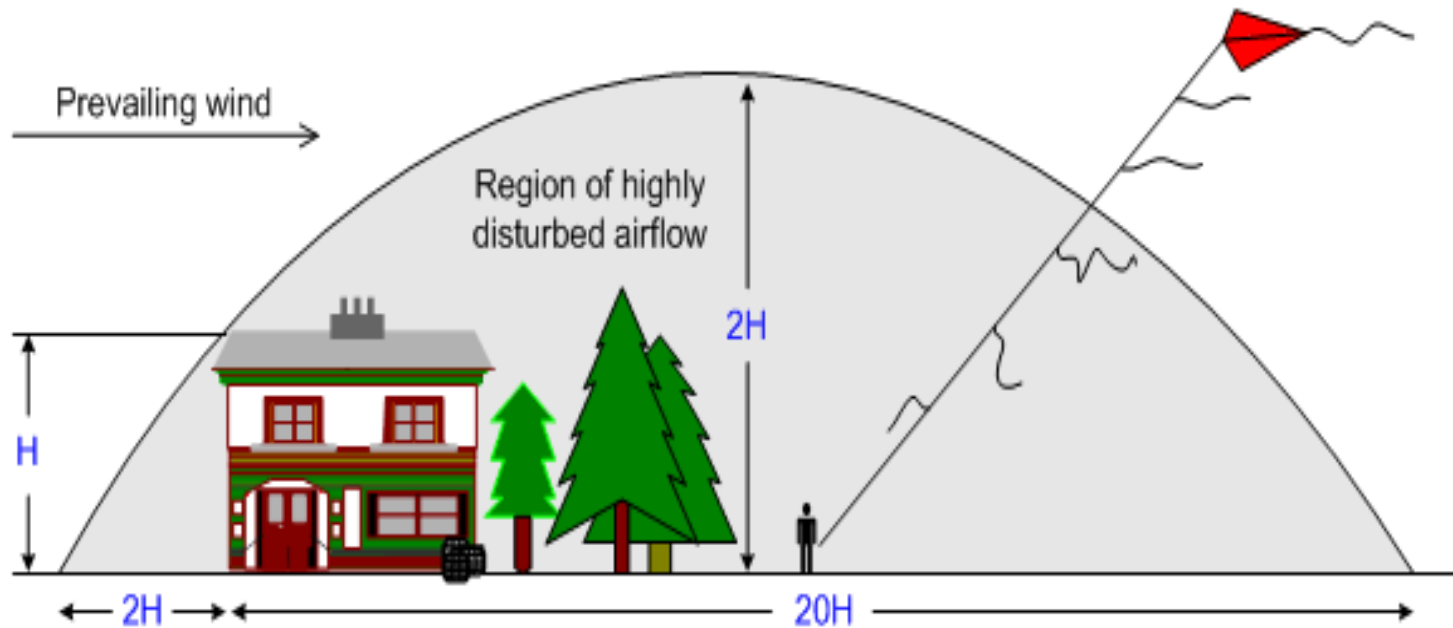

Avoid local obstructions

# Wind gusts

Rapid changes of wind speed in the atmosphere, also called wind gusts, cause **large fatigue loads** on wind turbines. These loads reduce the lifetime of wind turbine components

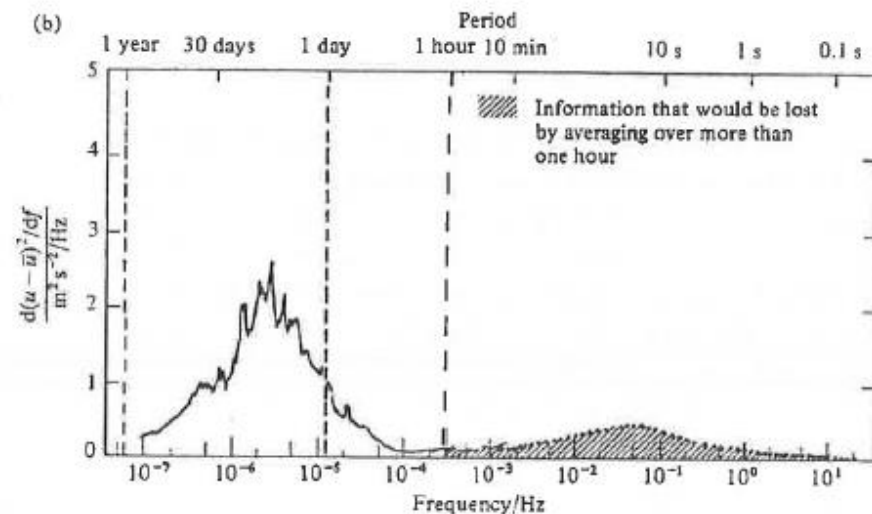
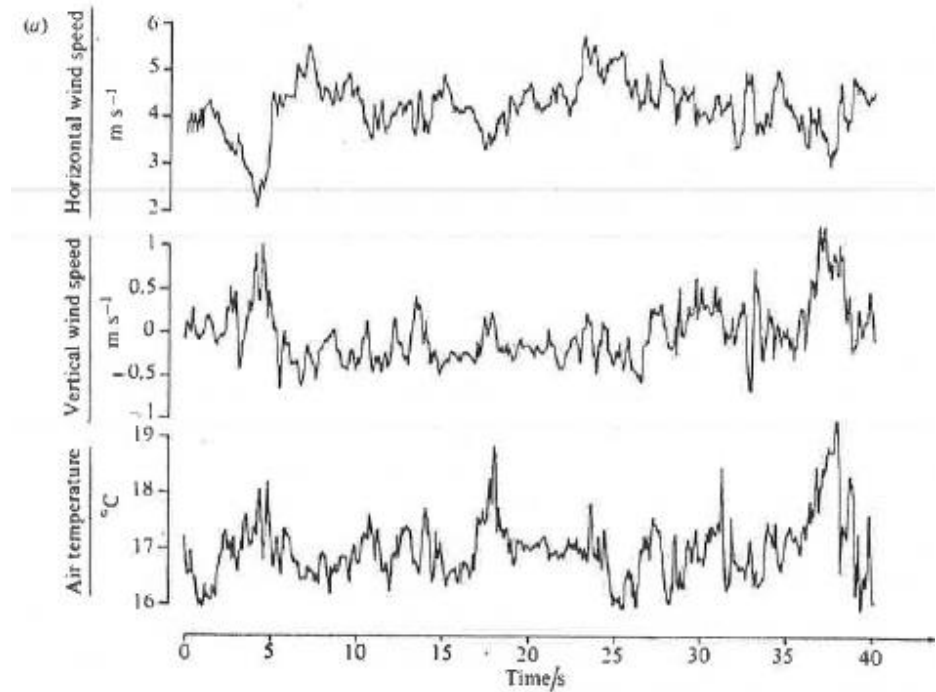

# Wind rose

A **wind rose** is a graphic tool used by meteorologists to give a succinct view of how wind speed and direction are typically distributed at a particular location.

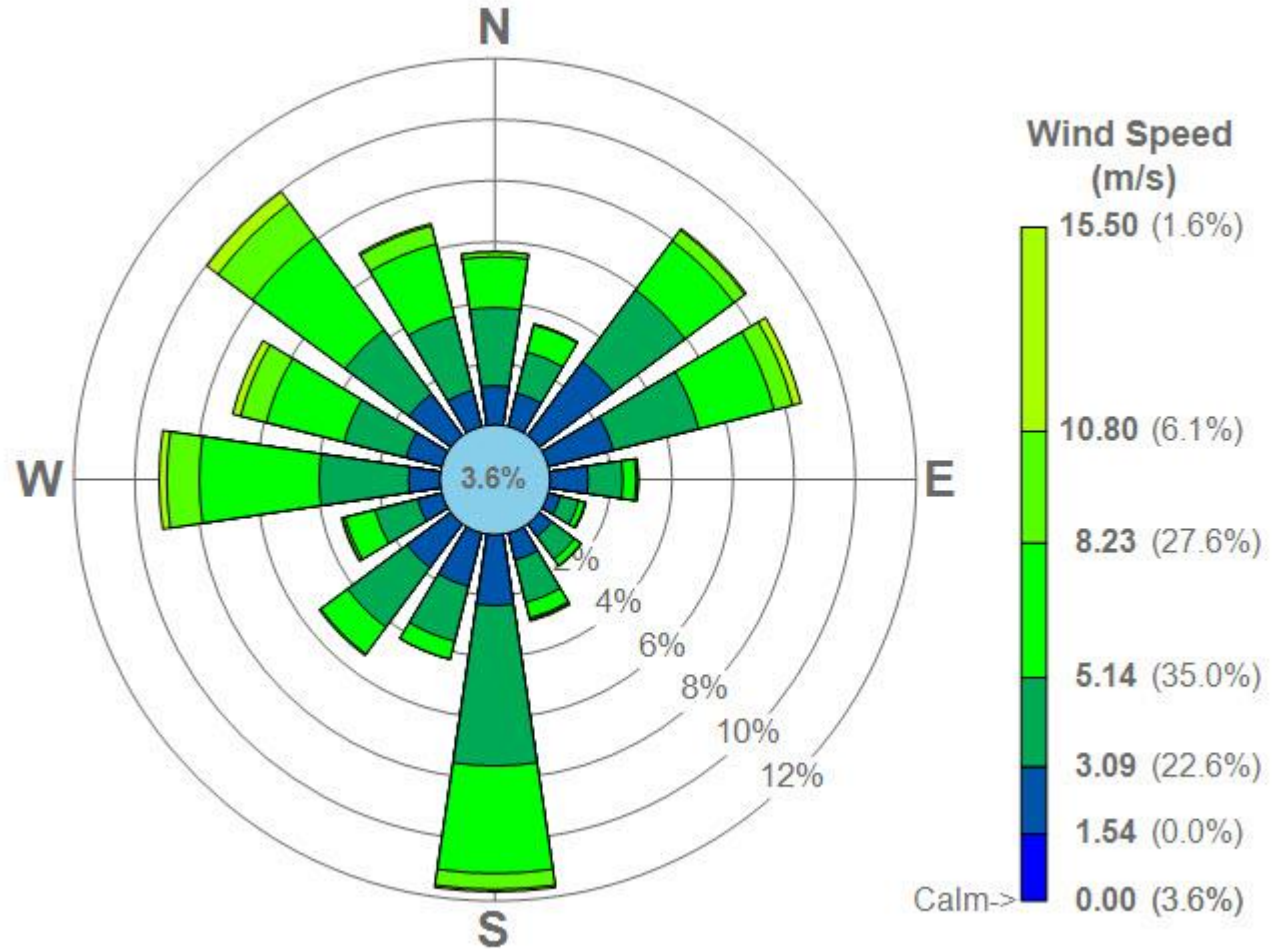

Made with BREEZE MetView - [www.breeze-software.com](http://www.breeze-software.com)

# Power in the wind

$$P_{in} = \frac{1}{2} \rho A v^3$$

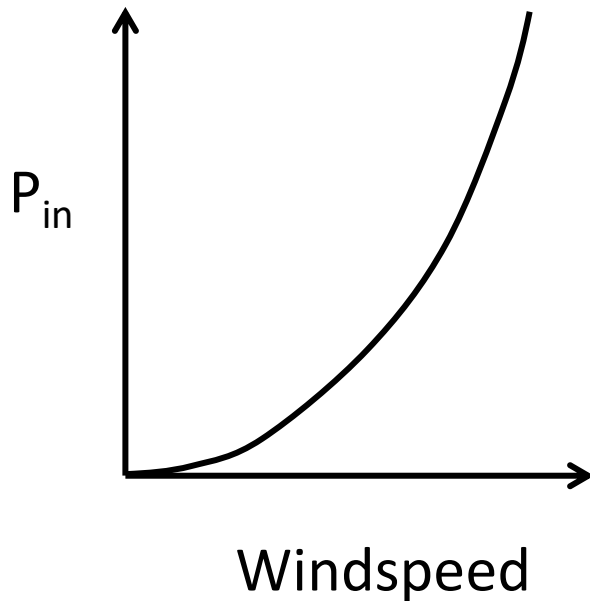

×

Power coefficient

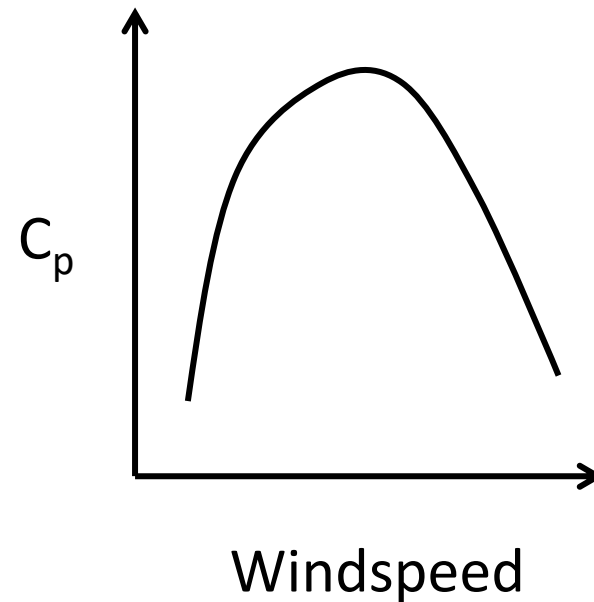

$$C_{p,max,theoretical} = 0.60 \text{ (Betz limit)}$$

$$C_{p,max,typical} = 0.35 - 0.4$$

# Power output

$$P_o = \frac{1}{2} C_p \rho A V^3$$

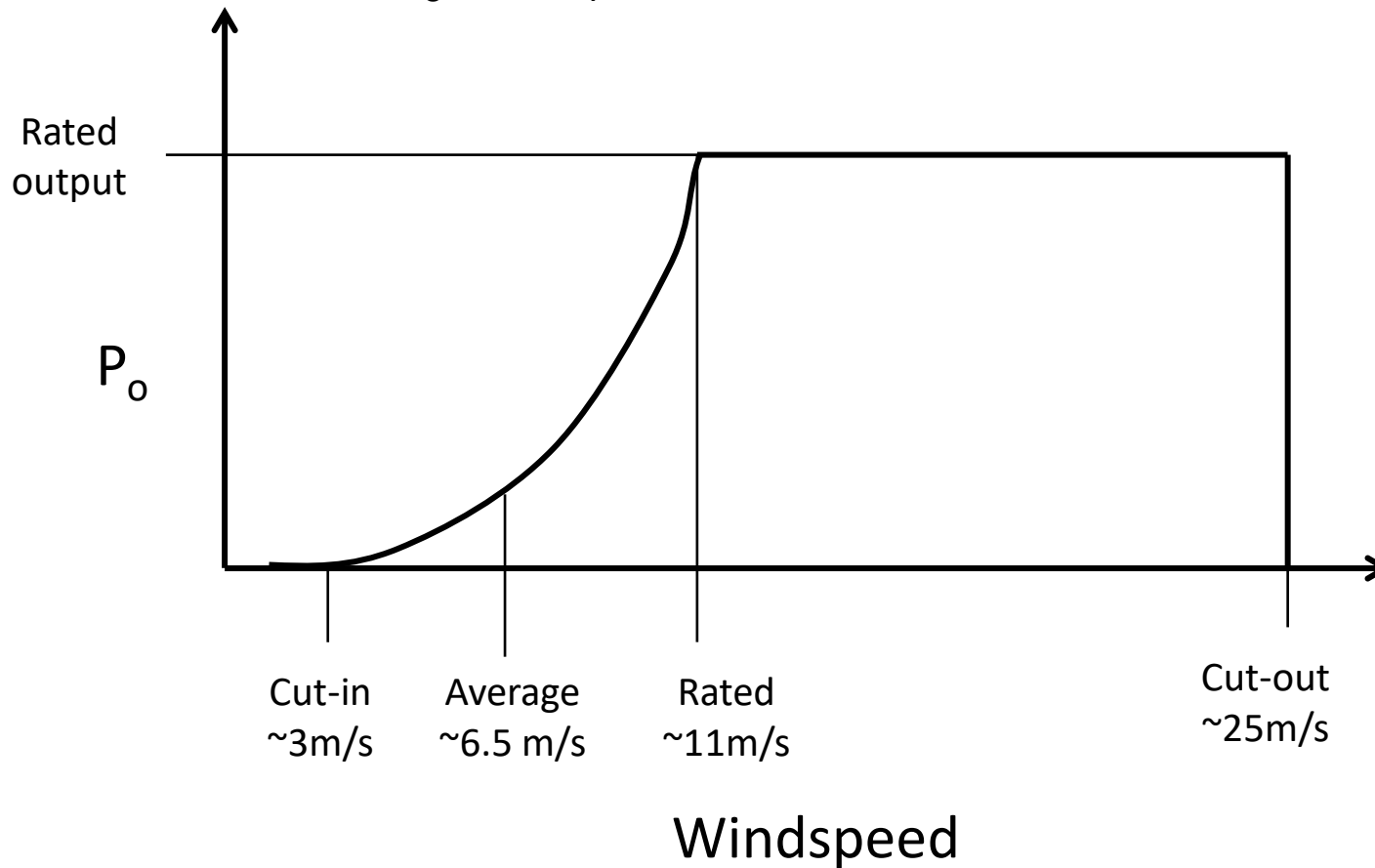

# Installation



# Installation



# Questions?